

Pneutorque® PTM-92 and PTM-119 Series Stall Models

The latest extension to the PTM tool range brings the speed advantage of the twin motor handle to higher capacity Pneutorque models.

Coupled with new gearbox designs, these new models deliver an ideal balance between robustness, speed and weight.



- Fast - 2700 N.m version has a free speed of 57 rpm for rapid bolt run-down time.
- Light weight - PTM-92-2700 weighs just 8.5kg. All models are fitted as standard with a light but robust aluminium reaction plate.
- Other reaction styles are available for maximum versatility.
- Quiet - less than 85 db(A) when under load.
- Non impacting - low vibration levels make these tools comfortable and safe to use.
- Square drive is quickly and easily replaceable.
- Bi-directional. The direction control knob is locked while the tool is running to prevent accidental damage to the gearbox.
- 'Soft Start' trigger control aids socket location and allows gradual and safe reaction location.
- For safety, gearbox can rotate independently from the handle so that reaction forces are not transmitted back to the operator.

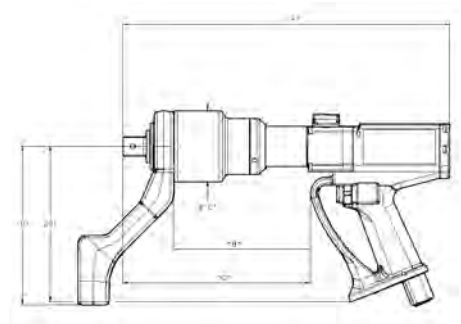

2700, 3500, 4500 and 6000 N.m Tools - Stall

Model	Square Drive	Part No.	Range		Free Speed †	Length 'A'	B	C	D	E	Tool Weight	Reaction Weight
	in		N.m	lbf.ft								
PTM-92-2700-B	1	18106.B08	540-2700	400-2000	57	387	178	243	205	92	8.5	1.35
PTM-92-3500-B	1	18107.B08	700-3500	520-2600	41	387	178	243	205	92	8.5	1.35
PTM-119-4500-B	1½	18108.B12	900-4500	660-3300	32	456	197	277	200	119	12.5	2.1
PTM-119-6000-B	1½	18109.B12	1200-6000	885-4500	25	456	197	277	200	119	12.5	2.1

† Speed at maximum air pressure.