

## Handtorque™ HT-52 and HT-72 Series

- Compact dimensions allow excellent access and easy, safe handling.
- Guaranteed accuracy of better than  $\pm 4\%$ .
- Anti Wind-Up Ratchet available, for easier and safer operation.
- HT-72 features a light weight aluminium reaction arm.
- A variety of alternative reaction styles are available for maximum versatility.
- Electronic torque transducers can be fitted to the HT-72 for precise torque monitoring. See page 83.
- Available in a variety of ratios and output square drive sizes.

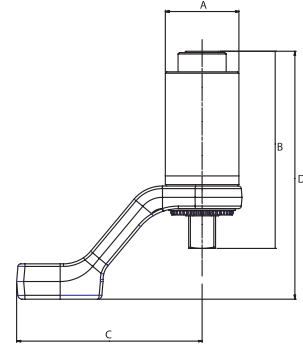

HT-52/22

HT-72/25

### HT-52 and HT-72 Series

Model	Part No.	Range		Ratio	Input Square	Output Square	A	B	C	D	Tool Weight	Reaction Weight
		N.m	lbf.ft									
HT-52/4.5	18087	1000	740	4.5:1	½	¾	52	115	131	150.3	1.02	0.85
HT-52/22	18051	1000	740	22:1	¾	¾	52	139	131	175	1.4	0.85
HT-52/22	18052	1000	740	22:1	½	¾	52	139	131	175	1.4	0.85
HT-52/22 Fitted with AWUR	18083	1000	740	22:1	¾	¾	52	150.1	131	186.3	1.6	0.85
HT-52/22 Fitted with AWUR	18084	1000	740	22:1	½	¾	52	150.1	131	186.3	1.6	0.85
HT-72/5	18014	1000	740	5:1	½	¾	72	144	165	188	2.4	0.66
HT-72/5	18015	1500	1100	5:1	½	1	72	144	165	188	2.4	0.66
HT-72/5	18017	2000	1450	5:1	¾	1	72	144	165	188	2.4	0.66
HT-72/25	18018	1000	740	25:1	½	¾	72	165	165	188	2.7	0.66
HT-72/25	18019	2000	1450	25:1	½	1	72	165	165	188	2.7	0.66
HT-72/25 Fitted with AWUR	18081	1000	740	25:1	½	¾	72	174	165	218	3.0	0.66
HT-72/25 Fitted with AWUR	18082	2000	1450	25:1	½	1	72	174	165	218	3.0	0.66

## Handtorque™ Small Diameter Series

Handtorque models HT30, 45 and 60 have all the features of the Standard Series, but have a higher torque output for a given gearbox diameter.

- Reduced diameter allows better access, particularly on pipe flanges.
- Reaction taken from high strength spline.
- Reaction foot can slide on the spline to allow for sockets of various lengths (except HT45).
- Anti Wind-Up Ratchet available on all models (except 5:1 ratios), allowing safer and more practical operation.
- HT45 has integral angle protractor for easy torque and angle tightening.



HT45/26

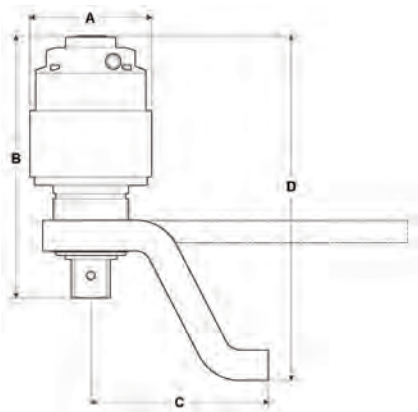

Alternative 350mm long, straight reaction plate; may be modified by customer to suit their applications.  
HT30 Part No. 16686  
HT45 and HT60 Part No. 16687



HT60/25

### Small Diameter Series

Model	Part No.	Range		Ratio	Input Square		A	B	C	D min	D max	Tool Weight	Reaction Weight
		N.m	lbf.ft		in	in							
30/5	18003	3000	2200	5:1	3/4	1	108	192	140	224.2	252.4	5.0	2
30/15 Fitted with AWUR	18004	3000	2200	15:1	1/2	1	108	210.9	140	243.2	271.4	7.0	2
30/25 Fitted with AWUR	18006	3000	2200	25:1	1/2	1	108	210.9	140	243.2	241.4	7.0	2
45/26 Fitted with AWUR	18037	4500	3300	26:1	1/2	1	108*	228	174	-	322	8.7	4
60/25 Fitted with AWUR	18008	6000	4400	25:1	1/2	1 1/2	119	256	174	311.5	337	10.6	4
60/125 Fitted with AWUR	18012	6000	4400	125:1	1/2	1 1/2	119	284.7	174	340.5	366	12.1	4

\*Maximum width 140mm.